

NOOMA

MOTO

This User Manual is Applicable to the Following Models

Hyperide-S (on-road model L1e)

Headlights, rearview mirrors
Turn signals and license plate lights, card
Aluminum alloy hubs, all-terrain tires

Driving Tips for Maximizing Range

The range of NOOMA electric motorcycles is similar to that of fuel-powered motorcycles, with variations mainly depending on how the vehicle is operated after each full charge. Besides driving habits, energy consumption may also be affected by environmental conditions, such as extremely cold or hot weather, and driving on steep mountain roads. To maximize the driving range on a single charge, we recommend reducing the speed appropriately and maintaining a constant speed to ensure maximum endurance.

To achieve the desired driving range, please pay attention to the following:

1. Avoid frequent and abrupt acceleration and deceleration.
2. Utilize energy recovery braking to extend range when safe to do so.
3. Maintain tires at the recommended inflation pressure (see Page 49).
4. Remove any unnecessary cargo to reduce the load.
5. The driving range may vary slightly in winter and summer.

Based on the above considerations and your driving habits, you can estimate your expected driving range.

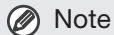

Note

When the vehicle is in an off-road condition, the driving range may decrease accordingly depending on the road condition.

Preface

We express our sincere gratitude for your choice of the Hyperide-S / Hyperide-R electric motorcycle, and wish you a safe and enjoyable ride on all your future journeys!

Please read this user manual carefully before operating the vehicle and keep it properly after reading. This user manual not only contains instructions on the correct operation, troubleshooting, and maintenance of the electric motorcycle but also guides you on how to protect your safety and the safety of others, preventing vehicle malfunctions and personal injuries.

This user manual was printed with the latest production information. As the product continues to improve, there may be slight differences between your electric motorcycle and this user manual. Please refer to the actual product.

In this user manual, to simplify content presentation and facilitate understanding, we have primarily used images of the Hyperide-S model for example demonstrations and function explanations. Therefore, when reading this manual, we recommend that you refer to your actual model and pay attention to the model-specific information noted in the text. If you have any questions about the content of this manual, please consult the authorized dealer where you purchased the vehicle.

NOOMA SCIENCE & TECHNOLOGY(WUXI)COMPANY LTD. reserves the right to revise this manual at any time without prior notice and assumes no responsibility for doing so.

Illegal modifications to the vehicle are prohibited.

No part of this user manual may be reproduced without the written permission of NOOMA SCIENCE & TECHNOLOGY(WUXI) COMPANY LTD.

© 2024 NOOMA SCIENCE & TECHNOLOGY(WUXI)COMPANY LTD., LTD. All rights reserved. First edition: August, 2024

Contents



1. Important Information

- 1.1 Overview4
- 1.2 Vehicle Information5

2. Riding Safety

- 2.1 Safety Guidelines7

3. Vehicle Introduction

- 3.1 Main Components 11
- 3.2 Instrument 13
- 3.3 Indicators 14
- 3.4 Handlebar Switches 15
- 3.5 Mechanical Key & NFC Card 17
- 3.6 Charging Port 18

4. Function Overview

- 4.1 Riding Modes 19
- 4.2 NFC Wireless Communication System20
- 4.3 Anti-theft Alarm System22
- 4.4 OTA Upgrade Function 23
- 4.5 Kinetic Energy Recovery Function23

- 4.6 Hill Hold Function23
- 4.7 Hill Descent Control Function 24

5. Riding Guidelines

- 5.1 Preparation Before Riding25
- 5.2 APP 26
- 5.3 Vehicle Power On / Off26
- 5.4 Riding28
- 5.5 Braking29
- 5.6 Parking30
- 5.7 Steering Lock31
- 5.8 Seat Cushion32

6. Battery & Charging

- 6.1 Power Battery34
- 6.2 Disassembly of Battery Pack36
- 6.3 Installation of Battery Pack36
- 6.4 How to Charge37
- 6.5 About the Charger39

7. Maintenance

7.1	Importance of Maintenance	42
7.2	Maintenance Schedule	43
7.3	Torque Management for Key Fasteners	45
7.4	Replacement of Parts	48
7.5	Motor and Controller	48
7.6	Inspection of Tire Pressure	49
7.7	Inspection of Tire Damage	49
7.8	Inspection of Tire Tread Depth	50
7.9	Spoke Wheel (Hyperide-R)	51
7.10	Inspection of Brake Fluid	52
7.11	Inspection of Brake Pads and Brake Discs	53
7.12	Side Stand	54
7.13	Throttle Grip	55
7.14	Replacement of Gear Oil	56
7.15	Inspection and Adjustment of Chain Slack	57
7.16	Fuse	58
7.17	Adjustment of Headlight Beam	59

8. Troubleshooting

8.1	Entire Vehicle Troubleshooting	60
8.2	Fault Code Table	62

9. Other Information

9.1	Maintenance of Electric Motorcycle	65
9.2	Storage of Electric Motorcycle	67
9.3	Transportation of Electric Motorcycle	68
9.4	Your Impact on the Environment	68

10. Technical Specifications

10.1	Technical Specification Table	69
------	-------------------------------	----

11. Schematic Circuit Diagram (Hyperide-S)





12. Index

1. Important Information



1.1 Overview

In this user manual, particularly important information is distinguished by the following symbols.

-  **Danger** **Failure to follow instructions will result in severe personal injury or death.**
-  **Warning** **Failure to follow instructions may result in serious personal injury or death.**
-  **Caution** **Failure to follow instructions may result in personal injury.**
-  **Note** **Take special precautions to prevent damage to the electric motorcycle or other property.**

Your safety and the safety of others are of utmost importance. As the vehicle owner, it is your responsibility to operate the vehicle safely and correctly.

To assist you in making safe decisions, we have provided safety symbols with associated operational steps and other information in this user manual.

These information are intended to alert you to potential hazards that could cause injury to you or others.

Please be sure to follow the instructions to operate and maintain your electric motorcycle safely and correctly!

Important Information

1.2 Vehicle Information

The vehicle identification number (VIN) and product label are unique identifiers for your electric motorcycle.

This information is required when registering your electric motorcycle. Dealers may also need them when ordering replacement parts.

You can refer to the locations indicated in the following figures to find the information for your vehicle.

■ VIN

The VIN is located on the right side of the steering column upright tube of the vehicle body, as shown in the figure.

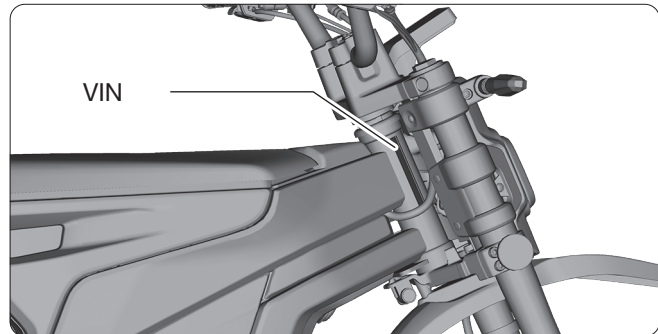

■ Product label (Hyperide-S)

The product label is located at the bottom of the frame, as shown in the figure.

Important Information



■ Motor number

The motor number is located underneath the motor, as shown in the figure.

2. Riding Safety

2.1 Safety Guidelines

■ Vehicle owner responsibilities

As the vehicle owner, it is your responsibility to operate the vehicle safely and correctly. Every rider should familiarize themselves with the following requirements before riding this vehicle.

- Riders should receive training on safe and correct riding techniques and obtain relevant certifications.
- Please comply with local traffic safety regulations when riding this vehicle. The Hyperide-R model is prohibited from being ridden on public roads.
- Please adhere to the warning instructions and maintenance requirements in this user manual.
- For safety reasons, it is not recommended to use this vehicle for competitive riding purposes.

■ Rider equipment

Please ensure that you wear a helmet, goggles, and high-visibility protective clothing that meet national certification standards. Take appropriate measures based on weather and road conditions while riding.

Helmet

We recommend choosing a helmet that meets national standards, has a bright color, and fits properly.

Not wearing a helmet increases the risk of severe injury or death in a collision.

Gloves

Highly abrasion-resistant full-finger leather gloves.

Boots

Protective boots that fit well and do not interfere with riding.

Clothing

High-visibility, protective long-sleeved shirts and durable pants (or a protective suit) suitable for riding.

■ Key points for safe riding

Before riding, ensure that you are in good physical condition and have your full attention. Do not consume alcohol or take medications before or during riding.

- Ride carefully with your hands always on the handlebars and your feet always on the footrests.
- Always be aware of the vehicles around you, stay alert, and be prepared to make emergency braking or take evasive

action at any time.

- Accelerate and brake smoothly, and make sure to activate the turn signals (Hyperide-S) before turning or changing lanes, and use the horn when necessary.
- Avoid riding while fatigued, as fatigue and negligence can impair your ability to make correct judgments and ride safely.
- Properly maintain your electric motorcycle to keep it in good condition.
- In wet conditions, the road surface will be slippery, and braking performance may be reduced, so ride with caution.
- In rainy or snowy weather, braking distances will be extended, so ride slowly and with caution. Avoid traveling in severe weather conditions such as heavy rain or strong winds.

■ Handling unexpected incidents

Personal safety is your top priority. If you or anyone else is injured, carefully assess the severity of the injury first and determine if it is safe to continue riding.

Call for emergency assistance if necessary. If the collision involves other people or vehicles, you must also comply with local laws and regulations.

If you decide to continue riding, turn off the vehicle's power and assess the condition of the electric motorcycle.

Check for damage to the power battery inside the vehicle, ensure that key nuts and bolts are tight, and inspect the handlebars, brakes, and wheels. Ride slowly and cautiously.

Your electric motorcycle may have suffered damage that is not immediately apparent. Please take it to a qualified repair shop for a thorough inspection as soon as possible.

After a collision, please note the following:

- If your electric motorcycle is severely damaged in a collision, there may be a risk of electric shock. Do not touch electrical components or their connecting wires.
- Avoid contact with brake fluid.

Riding Safety

Severe collisions may cause brake fluid leaks. Prevent brake fluid from coming into contact with your skin or eyes. Brake fluid contains harmful substances such as lead, benzene, and solvents. If inhaled or in contact with the skin, it may cause symptoms such as dizziness, headaches, and fatigue, and in severe cases, may damage liver and kidney function.

- Use a fire extinguisher suitable for electrical fires.



Warning

- Due to the use of a 72 V lithium battery in this electric motorcycle, improper handling during an accident may lead to incidents that can cause death or serious injury.
- In the event of an accident, please follow the methods and instructions outlined in this user manual.

■ Power battery

If the power battery emits an unusual odor, it may indicate a malfunction. Immediately park your electric motorcycle in a safe outdoor location away from flammable materials, turn off the power, and contact your authorized dealer. (For instructions on how to charge the power battery, see Page 37)

Do not attempt to disassemble or modify the power battery

yourself.

■ Brakes

Please follow these guidelines:

- Avoid excessive emergency braking.
Sudden braking can reduce the stability of the electric motorcycle.
If conditions permit, slow down before turning to avoid the risk of slipping.
- Be cautious when riding on surfaces with low friction.
Tires are more prone to slipping on such surfaces, requiring a longer braking distance.
- Repeated braking on long and steep downhill roads can cause the brakes to overheat severely, affecting braking performance.
- To achieve full braking effect, operate both the front and rear brakes simultaneously.
- It is normal for there to be slight noises after prolonged riding that do not affect performance.

■ Accessories and modifications

We strongly recommend against adding any additional accessories or modifying the original design of your electric motorcycle. Doing so may create potential safety hazards.

Modifying your electric motorcycle may also void your warranty



service and render your vehicle illegal for use on public roads (Hyperide-S).

Before deciding to add accessories to your electric motorcycle, please ensure that any modifications are both safe and legal.



Warning

- Improper accessories or modifications may cause accidents, putting you and others at risk of serious injury or death.
- Please follow all instructions in this user manual regarding accessories and modifications.

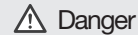

Danger

- Overloading, improper loading, or carrying excessive passengers can lead to accidents and cause serious injury or death.
- Please follow the loading guidelines provided in this user manual.

■ Loading guidelines

- Overloading can severely affect the maneuverability, braking, and stability of your electric motorcycle. Please avoid overloading and keep the load within the specified loading limits.

Maximum load capacity: 80 kg

- When carrying heavy loads, please ride at a safe speed.
- Securely fasten any items loaded on the motorcycle. Ensure that the load does not shift from side to side during driving and make adjustments as necessary.
- Please do not place items near the lights or motor.

3. Vehicle Introduction

3.1 Main Components

- 1 Rearview mirror (Hyperide-S)
- 2 Instrument
- 3 NFC card sensing area
- 4 Seat cushion
- 5 Taillight
- 6 Charging port
- 7 Rear shock absorber
- 8 Seat cushion lock
- 9 License plate light (Hyperide-S)
- 10 Rear reflector (Hyperide-S)
- 11 License plate holder (Hyperide-S)
- 12 Rear brake
- 13 Side stand
- 14 Driver footrest
- 15 Front brake
- 16 Front shock absorber
- 17 Side reflector

Vehicle Introduction



- 18 Front brake lever
- 19 Rear brake lever
- 20 Front turn signal (Hyperide-S)
- 21 Headlight
- 22 Horn
- 23 Front fender
- 24 Steering lock
- 25 Front wheel
- 26 Motor controller
- 27 Drive motor
- 28 Power battery compartment
- 29 Chain
- 30 Rear wheel
- 31 Stand cover (Hyperide-S)
- 32 Chain guard (Hyperide-S)
- 33 Rear fender (Hyperide-S)
- 34 Rear turn signal (Hyperide-S)

Vehicle Introduction

3.2 Instrument

■ Inspection of display

When the vehicle is powered on, all modes and numeric fields will be displayed. Each indicator will illuminate normally under the corresponding usage conditions.

If any of the above display areas do not illuminate, please contact your authorized dealer for troubleshooting.

Clock (Hyperide-S)

The clock displays in 24-hour format and is automatically calibrated by the BCM based on the network.

Bluetooth indicator

This indicator illuminates when a successful Bluetooth connection is established.

Side stand indicator

This indicator illuminates when the side stand is lowered.

Charging indicator

This indicator illuminates when the power battery is low and needs charging.

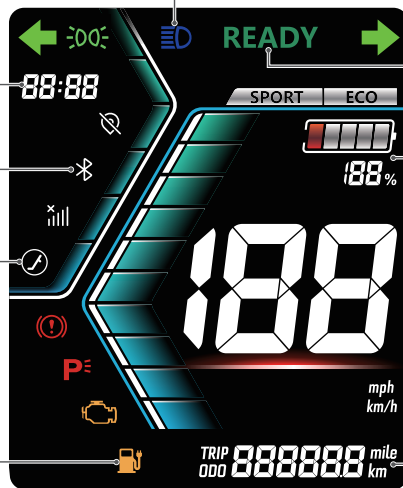

High beam indicator

This indicator illuminates when the high beam is turned on.

READY indicator

Indicates that the vehicle is ready for driving.

Battery level display

Displays the remaining battery level of the power battery.

Odometer information / fault code display

Displays the vehicle's travel mileage information, which can be toggled between TRIP (trip mileage) and ODO (total mileage). When a fault occurs in the vehicle, the corresponding fault code will be displayed in this area.



3.3 Indicators

■ Inspection of display

When the vehicle is powered on, all indicators will temporarily illuminate and then turn off.

If the indicators do not operate as described above, please contact your authorized dealer for troubleshooting.

Left turn signal indicator (Hyperide-S)

This indicator flashes when the left turn signal is activated.

GPS disconnected indicator (Hyperide-S)

This indicator illuminates when the GPS signal is disconnected.

Network disconnected indicator (Hyperide-S)

This indicator illuminates when the network signal is disconnected.

Fault indicator

This indicator illuminates when the vehicle's OBD detects a fault.

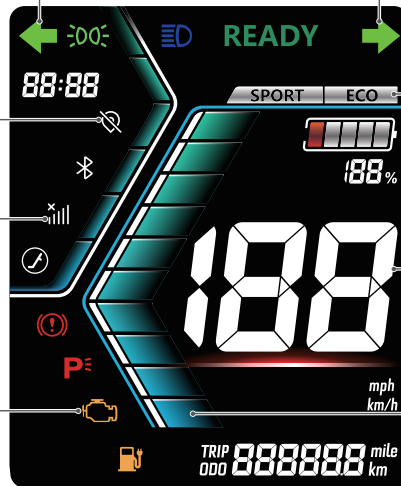

Right turn signal indicator (Hyperide-S)

This indicator flashes when the right turn signal is activated.

Riding mode display

Displays the selected riding mode.

Speedometer

Displays the current driving speed of the vehicle.

Current bar

The current bar will flow when the vehicle is driving; the greater the current output by the battery, the more segments will illuminate.

Vehicle Introduction

3.4 Handlebar Switches

■ Left handlebar switches

1 Headlight dimming button

Press the upper part of this button to turn on the high beam.

Press the lower part of this button to turn on the low beam.

2 Passing light button

When meeting or overtaking other vehicles, press this button to activate the passing light as a warning to the vehicles ahead.

3 Turn signal switch (Hyperide-S)

Toggle this switch to the left, causing the left turn signal to flash.

Toggle this switch to the right, causing the right turn signal to flash.

Press this switch to deactivate the turn signals.

4 Horn button

Press the horn button to sound the horn. Release the horn button to stop the horn from sounding.

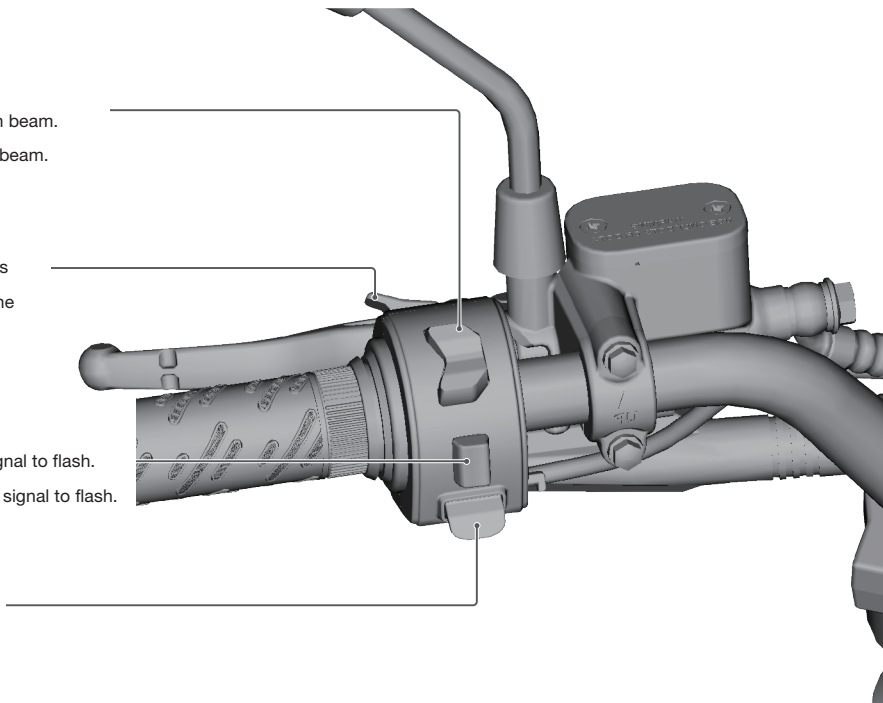

Vehicle Introduction

■ Right handlebar switches

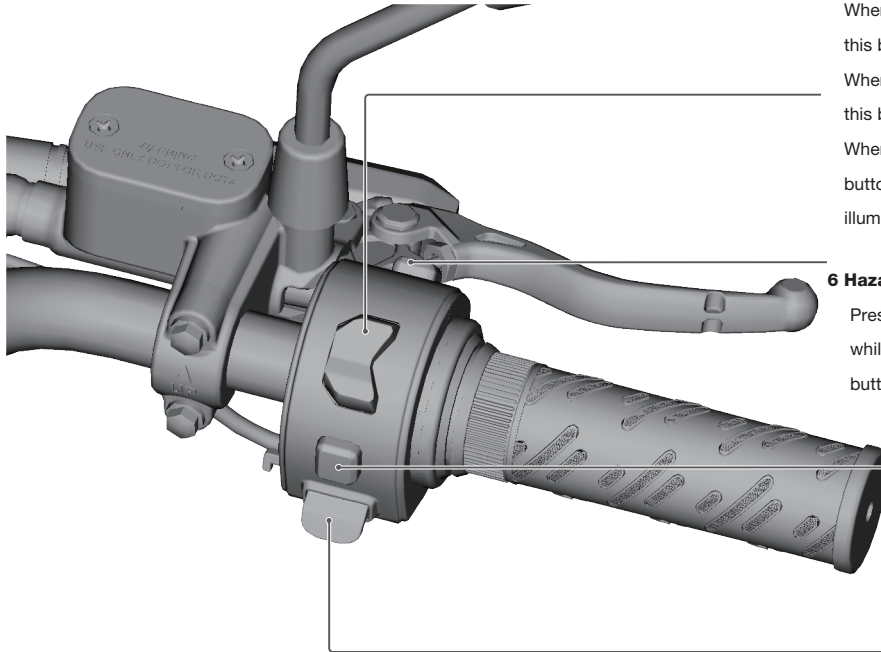

5 Emergency shutdown / P gear button / P

When the vehicle is not in P gear, pressing the upper part of this button will shut down the vehicle.

When the vehicle is not in P gear, pressing the lower part of this button will put the vehicle into P gear.

When the vehicle is in P gear, pressing the lower part of this button will release the P gear, and the READY indicator will illuminate, indicating that the vehicle is ready to drive.

6 Hazard warning light button / SOS (Hyperide-S)

Pressing this button once will activate the dual flashing light, while pressing it again will deactivate it. Press and hold this button to send out an SOS signal.

7 Power button

Long-pressing this button will turn off the vehicle.

8 Mode button **MODE**

Pressing this button will toggle between different riding modes.

Vehicle Introduction

3.5 Mechanical Key

two mechanical keys.

■ Use of mechanical key

The mechanical key provided with this vehicle can be used to unlock the seat cushion and lock the steering handle. Simply insert the mechanical key into the corresponding keyhole and rotate it in the specified direction to perform the corresponding operation.

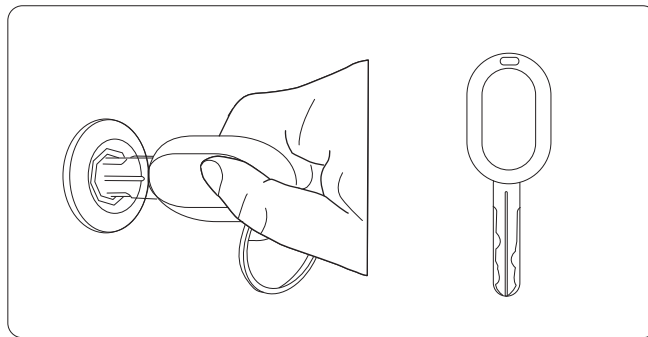



3.6 Charging Port

■ Power battery charging port

The power battery charging port is located on the left side of the body, as shown in the figure. Please open the charging port cover for using.

(For precautions related to power battery usage, see Page 35)

(For instructions on how to charge the power battery, see Page 37)

4. Function Overview

4.1 Riding Modes

■ Basic introduction

This electric motorcycle offers two riding modes for you to switch between:

- **SPORT mode:**
Sport mode. In this mode, the vehicle operates at full power with enhanced power output. For safety reasons, it is recommended to use this mode once you are familiar with the vehicle.
- **ECO mode:**
Economy mode. In this mode, the vehicle's maximum speed and power output are limited, making it suitable for use when you are not yet familiar with vehicle control or during long-distance rides.

■ Switching method

- 1 Power on the vehicle and ensure the side stand is retracted.
- 2 Shift the vehicle out of P gear, and once the READY indicator on the instrument illuminates, press the mode button on the right handlebar (see Page 16) to select the desired riding mode.

3 Confirm that the selected riding mode is displayed on the instrument. (see Page 14)



4.2 NFC Wireless Communication System

■ NFC card technical specifications

Operating frequency: 13.56MHz

Operating voltage: 3.3V (typical)

Standby current: 10uA (at 3.3V, NFC chip)

Operating temperature range: -30~85°C

Waterproof rating: IP67

Communication distance between NFC reader and non-contact NFC card: ≤25mm

■ Basic introduction

The NFC wireless communication system allows you to operate the power switch without using a traditional key.

This system performs bidirectional verification between the electric motorcycle and the NFC card to check if the NFC card is registered.

The NFC wireless communication system uses low-intensity radio waves. It may interfere with medical devices (e.g., pacemakers).

Note

- You should always carry the NFC card with you when mounting or dismounting the electric motorcycle or while riding.
- Please keep your NFC card in a safe place and avoid placing it casually to prevent loss.

Function Overview

■ Operating range

The NFC card operates within a range of 25 mm from the NFC reading area.

The NFC wireless communication system may not function properly in the following environments:

- When there are facilities nearby that generate strong radio waves or noise (e.g., TV towers, power stations, broadcasting stations, or airports).
- When the NFC card is carried together with wireless communication devices such as laptops, radios, or mobile phones.
- When the NFC card is in contact with metal or covered by metal objects.

NFC card usage precautions:

- Do not bend or squeeze the NFC card forcefully, or place heavy objects on it.
- Properly store the NFC card away from direct sunlight, high temperatures, and high humidity.
- Do not scratch or puncture it.
- Keep it away from magnetized products (e.g., magnetized keychains).

- Always keep the NFC card away from electrical products (e.g., TVs, radios, computers, or low-frequency massage devices).
- Keep the NFC card away from liquids. If it gets wet, immediately dry it with a soft cloth.
- When washing the electric motorcycle, keep the NFC card away from it.
- Do not burn it.
- Do not clean the NFC card in an ultrasonic cleaner.
- If fuel, wax, or grease gets on the NFC card, wipe it off immediately.
- Do not disassemble the NFC card.
- Do not lose your NFC card. If lost, you will need to register a new one. Contact your authorized dealer for assistance.
- Do not change the usage scenario or conditions, expand the transmission frequency range, or increase the transmission power (including adding additional RF power amplifiers) without authorization. Do not modify the transmitting antenna without permission.
- Do not cause harmful interference to other legitimate radio stations and shall not claim protection from harmful interference.



- It shall tolerate interference from industrial, scientific, and medical (ISM) applications that radiate RF energy or from other legitimate radio stations.
- If harmful interference is caused to other legitimate radio stations, immediately stop using the device and take measures to eliminate the interference before continuing use.
- Within the aircrafts as well as the electromagnetic environmental protection zones of radio astronomy observatories, meteorological radar stations, satellite earth stations (including tracking telemetry & control, ranging, receiving, and navigation stations), and other military and civilian radio stations and airports, which are designated in accordance with laws, regulations, and national standards, the use of micro-power devices shall comply with the regulations of electromagnetic environmental protection and the relevant industry authorities.
- It is prohibited to use various model remote controls within an area with a radius of 5000 meters centered on the midpoint of an airport runway.

4.3 Anti-theft Alarm System

■ Basic introduction

The anti-theft alarm system is designed to reduce the likelihood of vehicle theft. When the power switch is off and the system is set, the alarm will activate if the sensor detects any vibration or movement of the electric motorcycle.

The anti-theft alarm system utilizes low-intensity radio waves. It may interfere with medical devices (e.g., pacemakers).



Note

When the power battery in the electric motorcycle is low, the anti-theft alarm system may fail to operate.

■ Malfunction of anti-theft alarm system

If any of the following situations occur, it indicates that the power battery of the electric motorcycle is depleted or there is a system malfunction. Please consult your authorized dealer.

- The alarm does not sound.
- The alarm sounds but gradually fades away.
- The alarm continues to sound without stopping.

Function Overview

4.4 OTA Upgrade Function

This motorcycle is equipped with the OTA (Over-The-Air) upgrade function, which allows for the upgrading of the vehicle's firmware, configurations, and more through a wireless network. This capability is designed to improve the motorcycle's performance, functionality, or safety, enhancing your riding experience.

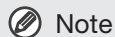

Note

- When performing a firmware upgrade, please ensure that the motorcycle's battery has sufficient charge to avoid interruption during the upgrade process, which may damage the firmware.
- If you encounter any issues during the OTA upgrade process, please contact your authorized dealer for inspection and troubleshooting.

4.5 Kinetic Energy Recovery Function

This motorcycle features a kinetic energy recovery function that converts kinetic energy generated during downhill riding, coasting, and braking into electrical energy through an energy recovery system. This function enables "charging while riding", extending the vehicle's driving range.

4.6 Hill Hold Function

The hill hold function is an auxiliary feature intended for use when parking on an uphill gradient, designed to assist in preventing the vehicle from rolling or slipping backwards on the slope.

■ Activating the function

While parked on an uphill gradient, continuously engage the brake lever for more than 1 second. If the vehicle tends to roll backwards when the brake lever is released, and the instrument displays "**R**", it indicates that the vehicle has entered hill hold mode.

■ Exiting the function

- ① Twist the throttle grip to move the vehicle forward.
- ② Press the P gear button to shift the vehicle into P gear mode.
- ③ Press the emergency shutdown button to turn off the vehicle.

■ Deactivating the function

The hill hold function can be deactivated through the APP.



Note

- This function is unavailable when the battery charge is below 5% or if the motor / controller temperature is excessively high.
- This function is solely intended as a riding aid and cannot serve as a substitute for mechanical parking brakes.

4.7 Hill Descent Control Function

The hill descent control function is an auxiliary system designed for use when descending steep slopes, aiming to assist the rider in controlling the vehicle's speed more safely and smoothly.

■ Activating the function

This function can automatically activate when the vehicle is on a downhill gradient and the rider has not twisted the throttle grip (i.e., not actively accelerating).

■ Exiting the function

- ① Twist the throttle grip.
- ② Engage the brake lever.

■ Deactivating the function

The hill descent control function can be deactivated through the APP.

Note

- This function is unavailable when the battery charge is above 95% or if the motor / controller temperature is excessively high.
- This function is solely intended as a riding aid and cannot serve as a substitute for mechanical parking brakes.

5. Riding Guidelines

5.1 Preparation Before Riding

Inspect the following items each time before using the vehicle to ensure that the electric motorcycle is in safe operating condition.

It is imperative to adhere to the inspection items, maintenance procedures, and maintenance schedule outlined in this user manual.

Inspection item	Inspection content	Reference page
Battery level	Check the remaining battery power of the power battery and charge it if necessary.	Page 13
Handlebar	Check for smooth operation at all steering positions.	-
Throttle grip	Check for the free play of the throttle grip.	Page 55
Brake lever	Check for smooth brake operation.	Page 29
Front / rear brakes	Check the brake fluid level and brake pad wear.	Page 52 - Page 53
Instrument / lights / switches	Check the proper functioning of the instrument, lights, and switches.	Page 13 - Page 15
Side stand switch	Check for proper functionality.	Page 54
Wheels and tires	Check for damage.	-
	Check tire condition, tread depth, and tire pressure, and adjust if necessary.	Page 49 - Page 50
Emergency shutdown switch	Check for proper functionality.	Page 16

5.2 APP

You can utilize the APP installed on your mobile phone to bind and manage your vehicle:

- Configure vehicle parameters
- Riding data statistics
- Fault diagnostic center
- Vehicle status diagnosis
- Set up electronic fence
- OTA upgrade center

To download the APP, search for “EZI” in the app store, or scan the QR code below to obtain it.

5.3 Vehicle Power On / Off

You can start your vehicle using the following methods.

1 Starting with an NFC card

Bring the NFC card close to the NFC sensing area located in front of the vehicle’s seat cushion (see Page 11). Upon successful verification, the vehicle’s power will be turned on.

Riding Guidelines

2 One-tap start using the APP

After binding your vehicle, open the mobile APP and establish a connection via remote or Bluetooth. Slide the "Power on / off" button located in the middle of the APP's home screen to the right to power on the vehicle.



To turn off the vehicle's power, you can use the following methods:

- 1 Touch the NFC sensing area with the NFC card that is already bound to your vehicle to power it off.
- 2 After binding your vehicle, open the mobile APP and establish a connection via remote or Bluetooth. Slide the "Power on / off" button located in the middle of the APP's home screen to the left to power off the vehicle.
- 3 Long press the power button on the right handlebar to power off the vehicle.

5.4 Riding

Before riding, please check your surrounding traffic environment, adjust the rearview mirrors, and turn on the turn signals (Hyperide-S) to indicate your direction of movement.

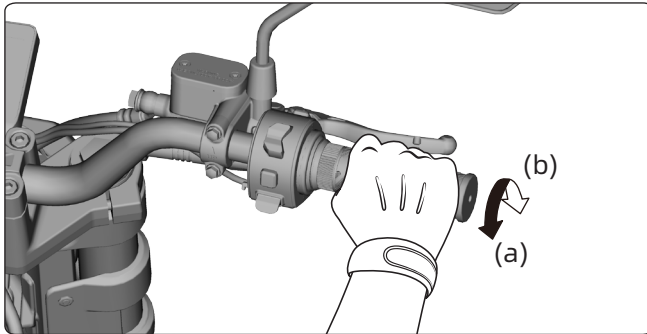

1 Power on and retract the side stand. (For information on how to power on the vehicle, see Page 26)

- The motor will not operate if the side stand is in the down position. Before riding, please make sure to retract the side stand.

2 Press the P gear button on the right handlebar once to deactivate the vehicle's P gear mode. Once the READY indicator illuminates, you can select your desired riding mode and start riding.

- If the READY indicator does not illuminate, the motor will not start, and you cannot operate your electric motorcycle.

3 Acceleration and deceleration.

Acceleration: Twist the throttle grip towards direction (a).

Deceleration: Twist the throttle grip towards direction (b).

4 Slow down before entering a curve and gradually twist the throttle grip towards direction (a) when exiting the curve.

Always use the turn signals before making a turn (Hyperide-S).

Riding Guidelines

5.5 Braking

Turn off the throttle grip and hold either the front or rear brake lever. The brake light at the tail of the vehicle will illuminate simultaneously with braking.

Warning

- Avoid excessive force or emergency braking (especially when the vehicle is leaning during a turn), as it may cause the vehicle to skid or roll over.
- Braking on wet roads can easily lead to slipping and create hazards. Please reduce speed and drive carefully.
- In situations such as descending long and steep slopes, repeated braking can cause the brakes to overheat severely, affecting braking performance. For safety, please operate both front and rear brakes simultaneously and use the brakes intermittently to reduce speed.

Note

- During driving, when you are approaching a turn or preparing to stop, apply the brakes in advance.
- Please activate the turn signal (Hyperide-S) in advance and keep a lookout for traffic from the side and rear. Apply pressure to the front and rear brake levers gently at first, then gradually increase it to achieve a controlled braking action.



5.6 Parking

Please use the side stand to park the electric motorcycle on a solid and flat surface, and lock the steering handle. If you must park on a slightly inclined or loose surface, please ensure the vehicle is stable and will not move or tip over.



1 Turn off the vehicle power (see Page 27).

2 Lower the side stand.

Gently lean the electric motorcycle to the left until its weight is concentrated on the side stand.

3 Turn the steering handle fully to the left and lock it (see page 31).

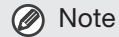

Note

When leaving the electric motorcycle, always turn off the vehicle power and lock the steering handle to reduce the risk of theft.

Riding Guidelines

5.7 Steering Lock

■ Locking the steering handle

- 1 Turn the steering handle to the fullest extent to the left.
- 2 Insert the mechanical key into the steering lock and turn it counterclockwise to lock the steering handle.
- 3 Gently shake the front end of the motorcycle to ensure the steering handle is properly locked.

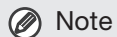

Note

This motorcycle is designed to lock the steering handle only to the left. Do not attempt to lock it to the right as this may cause damage to the vehicle.

■ Unlocking the steering lock

- 1 Insert the mechanical key into the steering lock and turn it clockwise to unlock the steering handle.
- 2 Turn the steering handle left or right to confirm smooth steering operation.

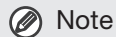

Note

- Please operate gently when turning the key and shaking the steering handle to avoid damaging components due to excessive force.
- If the steering lock is difficult to open, do not use force to unlock it as this may damage the lock and other motorcycle components. Please contact an authorized dealer for assistance.

5.8 Seat Cushion

■ Opening the seat cushion

1 Insert the seat cushion lock key into its lock, and turn it clockwise to unlock the seat cushion.

2 Gently lift the rear end of the seat cushion, press down on position [A] and hold, while simultaneously pulling the seat cushion towards the rear of the motorcycle.

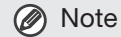

When opening the seat cushion, please ensure it is unlocked first and do not force it open to avoid damaging the seat cushion.

Riding Guidelines

■ Installing the seat cushion

- 1 First, insert the hooks on the seat cushion into the corresponding fixing buckles on the body, then press down on the seat cushion until it locks in place.
- 2 Gently pull up on the seat cushion to ensure it is securely locked in position.

6. Battery & Charging



6.1 Power Battery

This motorcycle model is equipped with a power battery located in the center of the frame (as shown on Page 12).



Warning

Do not attempt to disassemble or modify the power battery yourself.

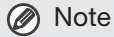

Note

- The battery of this motorcycle model is in a dormant state when it leaves the factory. It requires a charging activation before first use. This operation is recommended to be performed by your authorized dealer.
- It is not recommended to ride in environments below -5°C or above 45°C . If the ambient temperature is below -20°C or above 55°C , the output will be cut off. Additionally, please note that in low-temperature environments, there will be significant variations in the battery's actual capacity.

■ Basic introduction

The power battery has the following characteristics:

- With repeated charging and discharging, the battery capacity will gradually decrease. When the battery capacity decreases, even if the battery gauge shows it is fully charged, the distance you can travel will gradually shorten.
- Depending on your driving conditions and the lifespan of the electric motorcycle, the discharge performance will gradually decline. The driving range will be reduced when the electric motorcycle is operated in hot or cold conditions.

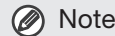

Note

- When the battery is fully discharged, the vehicle's anti-theft alarm system will malfunction, increasing the risk of theft. Please charge the power battery promptly.
- Due to self-discharge, the battery's charge will decrease even when the vehicle is not in use.
- To store the vehicle for an extended period while maintaining battery health, please use the official charger and charge the battery every three months to keep the battery pack's charge between 40% and 60%.
- If the vehicle's battery is fully discharged due to prolonged storage and cannot be started, please connect the charger to the vehicle and charge it for at least 30 minutes before attempting to start it again.
- Try to avoid discharging the battery completely before charging, as this will greatly affect the battery's lifespan.

Battery & Charging

Please follow these rules:

- Only use the original power battery provided with the motorcycle. Do not use batteries from other brands or models.
- Avoid exposing the power battery to water, beverages, or corrosive liquids.
- Keep the power battery away from heat sources, open flames, or flammable and explosive gases (liquids) and other hazardous environments.
- Prevent the power battery from experiencing excessive physical impact.
- Avoid metal objects from coming into contact with the terminals on the power battery.
- If you notice any abnormalities (such as the power battery overheating, smoking, or emitting an unusual odor), immediately stop using it, move away from the motorcycle, and contact your authorized dealer.

Warning

- Improper use of the power battery may result in electric shock accidents or fires, leading to death or serious injury.
- Do not attempt to disassemble used batteries. They should be recycled and disposed of by relevant professional departments.
- The battery warranty will be voided if any of the following conditions occur during the use and storage of the motorcycle:
 1. The motorcycle has been parked for more than 3 months without undergoing a maintenance charge. (see Page 34)
 2. The warranty will not apply to damage to the power battery caused by human factors, such as: accidental vehicle collisions, water immersion, fires, accidents, or unauthorized disassembly and modification by the user.
 3. The motorcycle's battery charge drops below 10% and is not charged for 7 days, resulting in severe over-discharge of the battery.
 4. The motorcycle exceeds the warranty period (the warranty duration is calculated from the date of purchase, as indicated on the purchase invoice).
 5. The battery is not used in accordance with the usage instructions in the user manual.



6.2 Disassembly of Battery Pack

- 1 Remove the seat cushion. (see Page 32)
- 2 Slide the latch on the battery pack harness connector press plate in the direction of the arrow ①, tilt the connector press plate up ②, grip the connector and pull it up vertically ③, and disconnect the harness connector.
- 3 Grip the handle and lift the battery pack upwards to remove it.

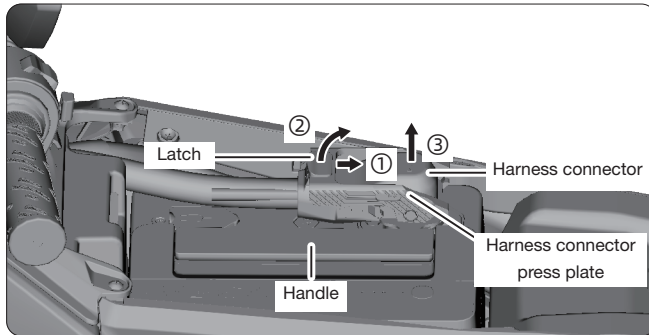

6.3 Installation of Battery Pack

- 1 Install the battery pack back into the motorcycle in its original orientation.
- 2 Connect the harness connector and press down on the harness connector press plate.
- 3 Reinstall the seat cushion. (see Page 32)

Battery & Charging

6.4 How to Charge

It is imperative to use an original or approved charger to charge the power battery. The charger used should match the battery's model.

■ Entire vehicle charging

- 1 Open the charging port cover.
- 2 First, connect the vehicle charging socket connector to the vehicle's charging port. Then, connect the charger's mains connector to the mains socket.
- 3 Once the battery is fully charged, first unplug the charger's mains connector from the mains socket, then disconnect the vehicle charging socket connector. Finally, close the charging port cover and store the charger safely.

■ External charging

- 1 Remove the battery pack. (see Page 36)
- 2 First, connect the charger's charging port connector to the charging port on the battery pack, and then connect the charger's power plug to the power socket.
- 3 Once the battery is fully charged, first unplug the charger's power plug from the power socket, then disconnect the connector from the battery pack's charging port. Close the charging port cover and store the charger safely.
- 4 Reinstall the battery pack into the vehicle (see Page 36), and power on the vehicle to confirm that the battery pack is working normally.

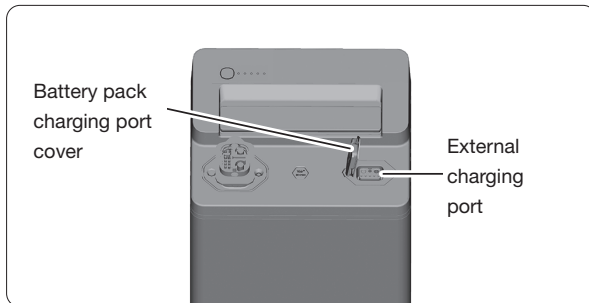

Charging environment

Please charge the power battery in the following locations:

- On a stable, level ground where the electric motorcycle can be securely parked.
- In an environment with a temperature between 0 °C and 40 °C.
- In a well-ventilated and non-humid location.
- In a place where it is legally permissible to charge.

Charging time

It takes approximately 4 hours to fully charge a power battery from a completely discharged state. In higher or lower ambient temperatures, the charging time may be longer. Do not charge for more than 12 hours to avoid affecting the battery's lifespan.

Note

The battery pack may not be able to charge immediately after high-power output or operation in high-temperature conditions. Please allow the battery pack to cool for 30 minutes or longer before starting the charging process. This is because the battery management strategy prohibits charging when the internal temperature is high, as it can shorten the battery pack's lifespan.

Battery & Charging

6.5 About the Charger

Please store the power battery charger in a location away from direct sunlight and rain. While charging, you can determine the charging status based on the charger's indicators.

Charger:



Indicators on the charger

Description of charger indicator status	
Indicator status	Description
Red and green indicators flashing	Battery not connected
Green indicator always on	Charging completed (fully charged)
Green indicator flashing	Charging completed (not fully charged)
Red indicator flashing	Charger malfunction
Red indicator always on	Charging in progress

If the battery or charger malfunctions, please contact your authorized dealer.

■ Operating instructions for charger

Please follow these rules when using the charger:

- When charging, first connect the charger to the mains power supply, and then to the charging port. A “clicking” sound is normal.
- To stop charging, first disconnect the power plug, and then unplug the connector from the vehicle body end.
- This charger is specifically designed for a particular motorcycle and should not be lent or used interchangeably with other vehicles to avoid damage.
- When charging, please use the original charger and a stable AC power supply. It is prohibited to use unstable power equipment to charge the vehicle. Stop charging when the battery is fully charged, and disconnect the charger from the power supply promptly after charging is complete.
- This charger is not waterproof. If the plug or body is submerged in water, immediately stop using it.
- When using the charger, keep it away from explosive gases and be cautious of flames or sparks.
- During operation, the charger generates heat. Ensure good ventilation in the surrounding environment and do not place it on sofas or other flammable surfaces.
- The charger must be properly grounded. If unsure whether the power socket is correctly grounded, please contact relevant personnel for inspection and confirmation.
- The charger contains high-voltage components and should not be repaired or modified internally without authorization. Contact after-sales personnel for repairs or replacements.
- Use the charger in a dry and well-ventilated environment, avoiding liquid, metal dust particles or other foreign matters from entering the charger, which may cause internal short circuits and damage.
- Do not charge the electric motorcycle when it is covered. Ensure good ventilation around the vehicle.
- Avoid charging in areas with a risk of thunderstorms.
- Do not plug too many power cables into one power socket.
- When plugging or unplugging the charger, do not pull the cable directly.
- Avoid repeated charging after the battery is fully charged.
- Before use, please read this manual carefully. If the red indicator flashes during charging, immediately stop charging, disconnect the charger from the power supply, and have it inspected by a professional.
- If the power supply is damaged or the charging system

Battery & Charging

malfunctions, please visit a designated repair shop for replacement and repairs.

Warning

If a vehicle or battery catches fire due to an accident, please follow these principles:

- If the power battery starts smoking, immediately evacuate from the vehicle area and contact the fire agent, preparing for firefighting.
- Use an ABC dry powder fire extinguisher or an electrical fire extinguisher to extinguish the fire. If the fire cannot be controlled, contact the fire agent immediately.
- After extinguishing the fire, please contact your dealer for disposal of the waste battery. Do not attempt to dispose of it yourself.
- Due to the different locations of the fire, the vehicle's voltage may not be cut off. Ensure that the power is disconnected after the fire is extinguished.

Note

This charger is only suitable for safe use in areas below 2000 meters above sea level.

7.1 Importance of Maintenance

It is crucial to keep your electric motorcycle in good maintenance and repair condition for your safety, the protection of your property, the preservation of vehicle performance, and the prevention of malfunctions.



- Failure to perform regular maintenance or properly troubleshoot before riding may lead to serious or fatal accidents.
- Please follow the inspection, maintenance recommendations, and maintenance schedule provided in this user manual.

Maintenance

7.2 Maintenance Schedule

Inspection item	Before each ride	New vehicle delivery 500km	Every 500km	Every 2000km	Every 3000km	Every 5000km	Every 10000km or 12 months	Every 20000km or 24 months
Tire pressure and tread depth	○						○/⊗	
Chain	○	✘		✘			○/⊗	
Clean chain and apply chain oil		✎	✎					
Chain guide			○			○/⊗		
Wear of front and rear sprockets						○		○/⊗
Visual inspection of brake fluid pipe and connectors	○							
Front and rear brake fluid	○						⊗	
Wear of front and rear brake pads	○						○/⊗	
Wear of front and rear brake discs	○							○/⊗
Wheel spoke	○	○/✘				✘		
Shock absorber oil leakage	○					✎		
Power battery level	○							
Power battery health check							○	
Instrument function display	○							
Combination switch function confirmation	○							
Lighting and signaling device	○							
Motor gear oil		⊗			⊗			

Maintenance



Steering column bearing and lubricating grease							🔧	○/🔄
Rear shock absorber multi-connecting rods mechanism bearing and oil seal						🔧	○/🔄	
Vehicle bearings								○/🔄
Bolt tightening						○		

○ Inspect 🛠️ Adjust 🔄 Replace 🔧 Maintain

The above content only represents the manufacturer's recommended maintenance items and intervals. Please conduct routine maintenance according to your actual usage habits.

Maintenance

7.3 Torque Management for Key Fasteners

Properly tightening the fasteners on your vehicle is crucial for maintaining its performance and safety. Correct tightening not only ensures the quality of connections between various components but also guarantees the stability and reliability of the vehicle under high-speed driving or aggressive maneuvering conditions. Please follow the instructions below to regularly inspect and tighten the fasteners on your vehicle to the specified torque values.

 **Note**

- Always use the correct tools when tightening fasteners on your vehicle to the specified torque values. Failure to do so may damage vehicle components.
- Be sure to tighten the fasteners to the recommended torque values and avoid over-tightening, which may cause damage to the components.

Maintenance



No.	Item	Thread size & type	Torque (N·m)	Recommended torque (N·m)	Remark
1	Brake lever assembly fastening bolt	M6×1.0	8 ~ 12	10	/
2	Rear shock absorber upper mounting nut	M10×1.25	39 ~ 49	44	Self-locking nut
3	Rear shock absorber lower mounting nut	M8×1.25	18 ~ 25	23	Self-locking nut
4	Rear brake caliper bolt	M8×1.25	24 ~ 29	26	Apply anaerobic locking agent before tightening
5	Rear brake fluid pipe bolt	M10×1.25	29 ~ 39	34	/
6	Rear disc brake fastening bolt	M8×1.25	39 ~ 44	42	Pre-applied anaerobic locking agent
7	Side stand switch bolt	M6×1.0	8 ~ 10	9	/
8	Side stand bolt	M10×1.25	5 ~ 15	10	Apply anaerobic locking agent before tightening
9	Footrest assembly limiting pin	M8×1.25	18 ~ 25	20	Tighten the limiting pin before assembly installation
10	Main footrest assembly mounting bolt	M8×1.25	34 ~ 39	37	/
11	Motor shaft nut (lower)	M8×1.25	29 ~ 39	34	Bolt head on left side of frame Matched with self-locking nut
12	Motor shaft nut (upper)	M8×1.25	29 ~ 39	34	Bolt head on left side of frame Matched with self-locking nut
13	Horn	M6×1.0	7.0 ~ 11	9	/
14	Front brake fluid pipe bolt	M10×1.25	29 ~ 39	34	/
15	Front brake caliper bolt	M8×1.25	24 ~ 29	26	Apply anaerobic locking agent before tightening
16	Front disc brake fastening bolt	M8×1.25	39 ~ 44	42	Pre-applied anaerobic locking agent

Maintenance

17	Lower bracket locking bolt	M8×1.25	20 ~ 25	23	/
18	Upper bracket locking bolt	M8×1.25	20 ~ 25	23	/
19	Upper cap locking bolt	M8×1.25	20 ~ 24	22	/
20	Steering gear locknut	M24×1.0	59 ~ 88	74	/
21	Steering gear dust nut	M26×1.0	1.9 ~ 2.9	2.4	/
22	Front axle nut	M12×1.25	64 ~ 74	69	Self-locking nut
23	Drive sprocket fastening bolt	M6×1.0	11 ~ 15	13	/
24	Rear flat fork shaft nut	M12×1.25	77 ~ 88	83	Self-locking nut
25	Rear axle nut	M12×1.25	78 ~ 98	88	Self-locking nut
26	Driven sprocket fastening bolt	M8×1.25	29 ~ 34	32	Apply anaerobic locking agent before tightening
27	Chain adjuster fastening nut	M8×1.25	16 ~ 26	21	Limiting nut only
28	Rear fender bracket (Hyperide-S)	M6×1.0	8 ~ 12	10	/



7.4 Replacement of Parts

To ensure vehicle reliability and safety, please use genuine parts or equivalents. When you need to replace parts, please consult your authorized dealer.



Warning

- Installing non-genuine parts may render your electric motorcycle unsafe and could lead to accidents causing serious injury or even death.
- Please use genuine parts or equivalents that are designed and certified for your electric motorcycle.

7.5 Motor and Controller

The controller of an electric motorcycle is a core component used to control the starting, running, and other functions of the vehicle's motor. It is one of the important parts on an electric motorcycle.

Please follow these rules:

- Do not privately modify the motor, as this can easily lead to serious consequences such as spontaneous combustion or traffic accidents.
- Avoid driving on roads with water depths exceeding the

motor's middle axis, as excessive water may seep into the motor and cause malfunctions.

- Frequently check the tightness of the motor. If you notice any loose screws, please contact a maintenance technician promptly for tightening.
- Keep the controller dry to prevent water infiltration during rainy days. Keeping the controller's exterior clean aids in heat dissipation and can extend its service life.
- Avoid prolonged overload operation, as this may cause aging of internal components within the controller, leading to issues such as reduced vehicle performance and insufficient power.

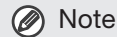

Note

If your vehicle is parked uncovered in rainy conditions for an extended period, check for water ingress in the controller and motor before driving. If such a situation occurs, it is recommended that you refrain from using the vehicle until the water ingress issue has been resolved.

Maintenance

7.6 Inspection of Tire Pressure

Check tire pressure visually and with a gauge at least once a month or whenever you feel the tire pressure is low.

Please check tire pressure when the tires are cool. The maximum tire pressures are as follows:

	Hyperide-S	Hyperide-R
Maximum pressure of front tire (cold)	175 kPa	200 kPa
Maximum pressure of rear tire (cold)	200 kPa	225 kPa



Warning

Operating this electric motorcycle with improper tire pressure may result in loss of vehicle control, causing severe personal injury or death.

7.7 Inspection of Tire Damage

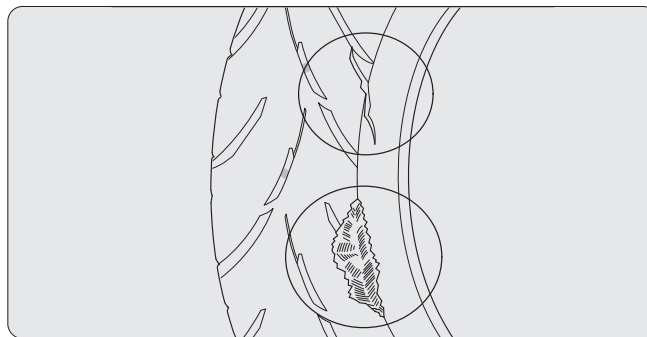

Inspect the tires for cuts, cracks, exposed fabric or tire cord, and for nails or other foreign objects embedded in the tire sides or tread.

Also, check the tire sidewalls for bulges or swelling.

7.8 Inspection of Tire Tread Depth

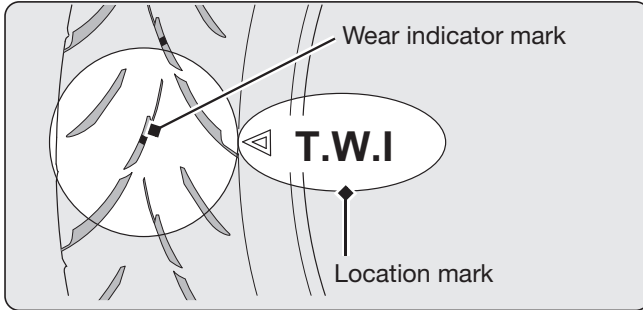

Inspect the tire tread wear indicator marks. If the wear indicator marks are visible, replace the tires immediately.

Minimum tread depth: 0.8 mm

! Caution

Riding with severely worn tires will degrade the electric motorcycle's driving performance and increase the risk of accidents.

Please follow these rules:

- Use recommended tires or equivalents with the same size, structure, speed rating, and load capacity.
- The Hyperide-R model is equipped with tubed off-road tires, while the Hyperide-S model uses tubeless tires. Do not install an inner tube in the tubeless tires of the Hyperide-S model, as excessive heat can cause the inner tube to burst.
- Do not overload the vehicle. Driving an overloaded vehicle can cause accidents.
- The replacement of all wheels and brake-related parts, including tires, should be handled by repair personnel with professional skills and operational experience.

⚠ Warning

- Installing unsuitable tires can affect the vehicle's handling and stability, leading to accidents that can cause serious injury or even death.
- Please use tires of the recommended size and type as specified in this user manual.

Maintenance

7.9 Spoke Wheel (Hyperide-R)

The inspection of spoke wheels is a crucial step in ensuring driving safety and enhancing the riding experience. Please follow the instructions below for operation.

- Keep the spokes clean by using a soft brush and mild cleanser to remove dirt, oil stains, and other contaminants. Dust and dirt can obscure issues such as rust or cracks.
- Visually inspect each spoke for bending, cracks, rust, missing spokes, or other damages. Ensure all spokes are evenly connected to the hub and rim, with no looseness or abnormalities.
- Check the tightness of the spoke caps. Loose caps may cause spokes to move during riding, leading to wheel imbalance and affecting riding stability.
- Inspect the rim for deformation, cracks, or excessive wear. Rim damage may affect the tension of the spokes and the balance of the wheel.
- Manually rotate the wheel to check for any bumping or smoothness issues. If present, it may indicate uneven spoke tension or rim deformation. While rotating the wheel, pay attention to any abnormal sounds, which may indicate loose or worn spokes.

Note

- Ensure the motorcycle's stability during any inspection and maintenance. It is recommended to use a maintenance stand to support the vehicle.
- When performing spoke wheel inspections, handle with care and use the correct tools for inspection and adjustment to avoid damaging vehicle components.
- If encountering complex issues that cannot be resolved independently, please visit an authorized dealer for assistance. Do not attempt to handle them yourself to avoid damaging the vehicle.

7.10 Inspection of Brake Fluid

Turn the steering handle and check if the brake fluid level is above the lower limit mark when it aligns horizontally with the mark line.

If the brake fluid level in the reservoir is below the lower limit mark or the free play of the brake lever exceeds the standard, please have your electric motorcycle inspected and repaired by your authorized dealer.

Recommended brake fluid: DOT 3/DOT 4 brake fluid or equivalent

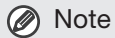

Note

Brake fluid can damage plastic and paint surfaces. If spilled, please wipe it off immediately and clean thoroughly.

Maintenance

7.11 Inspection of Brake Pads and Brake Discs

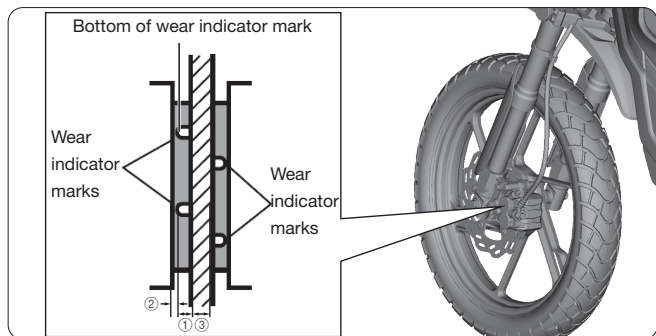

Inspect the condition of the front and rear brake pad wear indicator marks.

If the brake pads have worn down to the bottom of the indicator marks, they need to be replaced.

Inspect the wear condition of the front and rear brake discs.

If the thickness of the front and rear brake discs has worn down to the manufacturer's specified limit, they need to be replaced.

- ① Operating limit: 4 mm
- ② Brake pad operating limit: 1 mm
- ③ If the thickness of the brake disc is less than 3.0 mm, it needs to be replaced.

Warning

- Please have your authorized dealer replace the brake pads, and ensure that both the left and right brake pads are replaced simultaneously.
- Severe wear on the brake pads, if not replaced in a timely manner, may lead to accidents and pose a life-threatening risk to the user.

7.12 Side Stand

Inspection

- Check if the side stand operates smoothly. If the side stand is stiff or makes abnormal noises, clean the pivot area and lubricate the pivot bolt with clean grease.
- Inspect the spring for any damage or loss of elasticity.
- Sit on the electric motorcycle and retract the side stand. Start the motor and lower the side stand to the fullest extent. At this point, even if you turn the throttle grip, the motor will not operate.

If the motor does not stop operating after lowering the side stand and you are still able to ride the electric motorcycle, please have it inspected and repaired by your authorized dealer.

Maintenance

7.13 Throttle Grip

Inspection

With the vehicle's power turned off, check if the throttle grip moves smoothly from fully closed to fully open.

If the throttle grip does not operate smoothly or fails to return to its original position automatically, please have it inspected and repaired by your authorized dealer.



7.14 Replacement of Gear Oil

- 1 Use a maintenance stand to lift the vehicle, ensuring that both the front and rear wheels are off the ground.
- 2 Use appropriate tools to remove the lower motor guard and the right protective panel. Place an oil tray underneath the motor to collect the gear oil. Remove the oil drain / fill bolt and allow the gear oil to drain completely.
- 3 Tilt the motorcycle on its side and then add 60 ml of gear oil to the motor.
- 4 Reinstall the oil drain / fill bolt.

Oil type: GL-4 85W-90

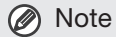

Note

Due to the specialized process involved in changing gear oil, we recommend that you have it handled by an authorized dealer.

Maintenance

7.15 Inspection and Adjustment of Chain Slack

Inspection

Standard chain slack: 15 - 25 mm

Adjustment: Loosen the rear axle nut and the locknut. Adjust the chain slack by loosening or tightening the adjusting bolt. While adjusting the chain, ensure that the front and rear sprockets are aligned in a straight line to prevent improper adjustment from affecting the chain's lifespan. After adjustment, retighten the rear axle nut and the locknut.



An overly loose or tight chain may cause the chain to come off or break, posing a potential safety hazard to you. Therefore, please regularly visit an authorized service station for inspection and adjustment.

7.16 Fuse

The electrical system of this motorcycle is equipped with multiple overcurrent protection devices, among which the fuse is a one-time protective device designed to safeguard the circuits on the motorcycle. If you find that certain electrical components on the motorcycle stop working, please check if the fuse has blown.

■ Inspection and replacement of fuse

The fuse of this motorcycle is located at the rear of the vehicle, underneath the seat cushion. Please follow these steps to inspect and replace the fuse:

- 1 Completely disconnect the power to the motorcycle.
- 2 Open and remove the seat cushion. (see Page 32)
- 3 Remove the main frame protective panel.

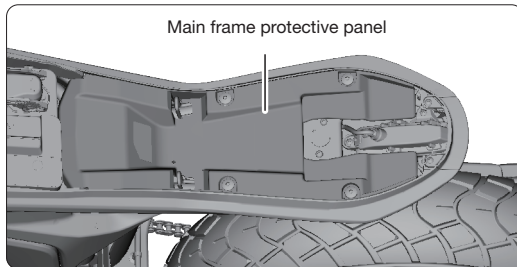

- 4 Pull off the fuse cap and check the condition of fuse 1 and fuse 2.

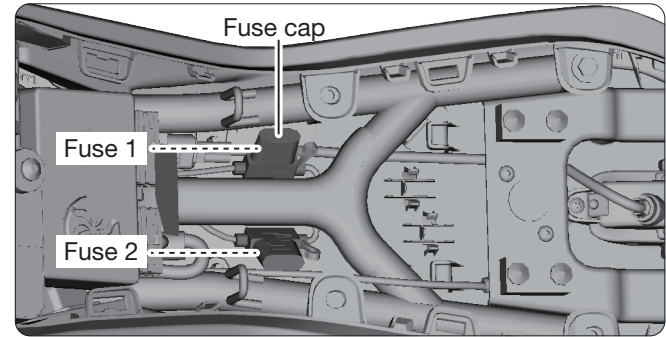

- 5 If a fuse has blown, replace it with a fuse of the same specification.

ⓘ Note

- If a fuse frequently blows, please contact your dealer to inspect the electrical system.
- When replacing a fuse, always use a fuse of the same specification.

Maintenance

7.17 Adjustment of Headlight Beam

In dark or low-light conditions, the headlights of an electric motorcycle are the primary source of illumination. If the headlight beam angle is incorrect, it can cause the beam to point too close or too far, directly affecting the driver's visibility and increasing the risk of driving. Therefore, please regularly check if the headlight beam angle is correct and adjust it if necessary.

■ Inspection and adjustment method

The headlight beam adjusting screw is located on the back of the headlights, as shown in the figure. Please follow these steps to adjust it:

- 1 Place the motorcycle upright on the ground and turn on the low beam of the headlights.
- 2 Sit on the driver's seat cushion and check if the beam angle is correct.
- 3 Use a Phillips screwdriver to adjust the beam angle by turning the beam adjusting screw left or right until the desired beam angle is achieved.

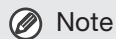

Note

- Changes in the motorcycle's overall angle can affect the headlight angle. After altering the motorcycle's overall angle, please be sure to check and adjust the headlight beam angle.
- Ensure that the beam adjustment complies with local traffic regulations and relevant standards.

8. Troubleshooting



8.1 Entire Vehicle Troubleshooting

No.	Item	Cause of fault	Troubleshooting method
1	Unable to start	<ol style="list-style-type: none">1. Battery plug not properly connected2. Battery over-discharged	<ol style="list-style-type: none">1. Check if the plug is properly connected2. Promptly activate and charge the undervoltage battery with a charger.
2	Unable to ride after power-on	<ol style="list-style-type: none">1. Side stand not retracted2. Insufficient battery power3. P gear switch not pressed4. Abnormal brake lever return or brake switch failure	<ol style="list-style-type: none">1. Retract the side stand2. Charge the battery promptly3. Press the P gear switch to deactivate P gear4. Check the brake lever or brake switch
3	Insufficient riding power or reduced mileage	<ol style="list-style-type: none">1. Low tire pressure2. Low battery power3. Severe overloading4. Poor braking performance5. Battery aging6. Excessively high temperature of motor / controller / battery7. Battery operating temperature too low or too high	<ol style="list-style-type: none">1. Inflate the tires to the recommended pressure2. Charge the battery promptly3. Operate the vehicle within the recommended load capacity4. Inspect the brake system in time, and replace the brake pads regularly5. Replace the battery6. Wait for accumulated heat to dissipate before riding7. Ride within the recommended ambient temperature
4	Unable to charge	<ol style="list-style-type: none">1. Non-original charger used2. Charger plug fallen off or loose3. Battery over-discharged	<ol style="list-style-type: none">1. Use the dedicated charger for charging2. Ensure the charger plug and battery are securely connected3. Activate the battery

Troubleshooting

5	Horn does not sound	<ol style="list-style-type: none">1. Horn connector loose2. Horn failure3. Left handlebar switch failure	<ol style="list-style-type: none">1. Check the horn connector for proper insertion2. Replace the horn3. Replace the left handlebar switch
6	Lights do not illuminate	<ol style="list-style-type: none">1. Light connector loose2. Light failure	<ol style="list-style-type: none">1. Check the light connector for proper insertion2. Replace the lights
7	Other	Instrument displays fault codes	Refer to the fault code table for troubleshooting suggestions





8.2 Fault Code Table

No.	Fault code	Cause of fault	Solution
1	F0	Throttle grip abnormality	Check for shorts, loose connections, or broken wires in the throttle grip, controller wiring, and connectors
2	F1		
3	F2		
4	F3	P gear switch abnormality	Check for shorts in the right handlebar switch, controller wiring, and connectors
5	F4	Brake switch abnormality	Check for shorts in the brake switch, controller wiring, and connectors
6	F5	Controller input overvoltage (software)	Check battery status and try restarting to resolve
7	F6	Controller input undervoltage (software)	Check battery status and recharge the battery
8	F7	Controller internal voltage abnormality (software)	Contact after-sales service or a repair station
9	F8	Controller internal voltage abnormality (software)	Contact after-sales service or a repair station
10	F9	Controller input overcurrent	Try restarting to resolve. If it occurs frequently, contact after-sales service or a repair station
11	FA	Controller phase line overcurrent (software)	Try restarting to resolve. If it occurs frequently, contact after-sales service or a repair station
12	Fb	Motor overspeed protection	Ride safely and avoid speeding on downhill slopes.
13	FC	Controller overtemperature protection	Allow to cool by resting before riding again
14	Fd	Motor overtemperature protection	Allow to cool by resting before riding again
15	FE	Motor stall protection	Check the transmission for obstructions preventing motor rotation, and remove any obstructions and restart
16	E0	Motor overload protection	Check if the riding conditions meet the vehicle's maximum performance requirements
17	E1	Motor temperature sensor abnormality	Check for shorts, broken wires, or loose connections in the motor, controller wiring and connectors

Troubleshooting

No.	Fault code	Cause of fault	Solution
18	E2	Controller temperature sensor abnormality	Try restarting. If unresolved, contact after-sales service or a repair station
19	E5	Controller phase current sensor abnormality	
20	E6	Controller phase current sensor abnormality	
21	E7	Controller phase line overcurrent (hardware)	
22	E8	Controller phase line overcurrent (hardware)	
23	E9	Controller input overvoltage (hardware)	
24	EA	Controller input overcurrent (hardware)	
25	Eb	Motor position sensor abnormality	Check for shorts, broken wires, or loose connections in the motor, controller wiring and connectors
26	EC	Controller phase loss fault	Check for broken wires or loose connections in the three-phase line connections between the motor and controller
27	Ed		
28	EE		
29	d0	Controller general fault (hardware)	Contact after-sales service or a repair station
30	d9	NFC abnormality	Check for shorts, broken wires, or loose connections in the NFC antenna, body controller wiring, and connectors
31	dA	Bluetooth abnormality	Try restarting. If unresolved, contact after-sales service or a repair station
32	1d3	Body controller 72V voltage output overload	Check for shorts in the body controller wiring and connectors
33	1d4	Body controller 72V voltage output short circuit	
34	1d5	Body controller 72V input fault	Check for loose connections or broken wires in the body controller wiring and connectors
35	1dA	Controller communication abnormality	Check for shorts, loose connections, or broken wires in the controller wiring and connectors

Troubleshooting

No.	Fault code	Cause of fault	Solution
36	1dd	Battery communication abnormality	Check for shorts, loose connections, or broken wires in the battery wiring and connectors
37	A9	Instrument drive abnormality	Replace the instrument
38	AA	Instrument communication abnormality	Check for shorts, loose connections, or broken wires in the instrument wiring and connectors
Note:		<p>The fault code is displayed in the mileage area, as shown in the figure below</p>  <p>Two-digit fault code display</p>  <p>Three-digit fault code display</p>	

9. Other Information

9.1 Maintenance of Electric Motorcycle

Regular cleaning and polishing ensure the longevity of your electric motorcycle. A clean electric motorcycle makes it easier to spot potential faults.

It should be particularly noted that seawater and salt used to prevent icing on the road can accelerate the formation of corrosion.

After riding on coastal roads or surfaces treated with such substances, thoroughly wash your electric motorcycle.

- **Cleaning**

Wait for the motor, brakes, and other high-temperature components to cool before cleaning.

1 Thoroughly rinse your electric motorcycle with a hose to remove loose dirt.

2 If necessary, use a sponge or soft towel dipped in a gentle cleaner to remove the dirt on it.

- Be particularly careful when cleaning headlight, instrument, panel, and other vulnerable components to avoid scratching them. Avoid letting water enter electrical components.

3 Rinse your electric motorcycle thoroughly with plenty of

clean water and dry it with a clean, soft cloth.

4 After drying, lubricate all moving parts.

- Ensure no lubricant spills onto the brakes or tires. Brake discs and brake pads contaminated with lubricant will significantly reduce their braking performance, potentially leading to accidents.

5 Apply a layer of wax to the plastic exterior parts to prevent corrosion.

- Avoid using products containing strong detergents or chemical solvents. These substances can damage the metal parts, paint, and plastic components of the electric motorcycle.

- Do not wax the tires or brakes.

- If your electric motorcycle has components with a matte paint finish, do not apply wax to these matte surfaces.

- **Cleaning precautions**

Follow these guidelines when cleaning:

- Do not use a high-pressure water gun: High-pressure water washers may damage moving parts

Other Information

- and electrical components, rendering them inoperable.
- Dry the brakes:
Water can reduce braking performance. After cleaning, ride at low speeds and intermittently use the brakes to help dry them.
- Do not wash the power battery or battery compartment in water or with cleaning agents.
This may cause starting and functional failures.
- Do not directly rinse the area under the saddle with water:
This can cause water to enter electrical components, leading to malfunctions.
- Do not directly rinse near the headlights:
After cleaning or riding in the rain, the inner cover of the headlights may temporarily fog up. This does not affect the headlights' functionality.
However, if you see a significant amount of water or ice accumulated inside the cover, have your authorized dealer inspect your electric motorcycle.
- Do not use wax or polishing compounds on matte-finish surfaces.
Clean them with a soft cloth or sponge, plenty of water, and a neutral detergent. Then, dry them with a soft, clean cloth.

- Aluminum component
Aluminum corrodes when exposed to dirt, mud, or road salt. Regularly clean aluminum components and follow these guidelines to prevent scratches:
 - Do not use hard brushes, steel wool, or cleaners containing abrasives.
 - Avoid riding over curbs or scraping against them.
- Panel
Follow these guidelines to prevent scratches and damage:
 - Gently clean with a sponge and plenty of water.
 - Use a diluted detergent to clean and rinse thoroughly with plenty of water to remove stubborn dirt.
 - Avoid getting gasoline, brake fluid, or detergents on the instruments, panels, or headlights.

Note

- Improper cleaning may damage vehicle components. Always follow the instructions in this manual for cleaning.
- To extend the lifespan of the electric motorcycle, perform regular cleaning and maintenance, and dry it as soon as possible after cleaning.
- The tires of the vehicle only need to be cleaned and do not require any tire maintenance products, as this may reduce the friction between the tires and the ground and even cause premature aging of the tires.

Other Information

9.2 Storage of Electric Motorcycle

- If the vehicle is not to be used for an extended period (over 30 days), it is recommended to discharge the battery to approximately 60% to 80% of its capacity, and then disconnect the connecting wire between the electric motorcycle and the battery pack.
- The battery pack will also discharge slowly when stored. Please check the battery pack's charge level at least once a month. If the charge drops below 30%, recharge it to 60%-80%. When you are ready to use the electric motorcycle again, fully charge the battery pack to restore it to good operating condition. For more information on batteries and charging, see Page 34.
- To extend the lifespan of the power system, store your electric motorcycle in a cool, well-ventilated area. Storing the electric motorcycle in hot or humid conditions may shorten the lifespan of the battery pack and electrical system.

Recommended storage temperature: 0 to 25°C

Warning

Only professionally trained technicians are authorized to provide maintenance services for the battery pack. Please note that unauthorized handling of internal battery pack components can be extremely dangerous. Do not attempt to disassemble the battery pack yourself. In case of any issues, please visit an authorized dealer for inspection and repair.

Note

Never store your electric motorcycle with less than 30% battery charge. Discharging the battery pack below 30% for extended periods may shorten its lifespan or even cause damage. Damage to the battery pack caused by over-discharge or prolonged low charge states is not covered by the warranty.

- Before storing the electric motorcycle, clean it and wax all painted surfaces (except matte finishes). Apply anti-rust oil to all chrome-plated parts.
- Use a maintenance stand to support your electric motorcycle and place blocks underneath to keep both tires off the ground.
- If you park your electric motorcycle outdoors, consider using a full-body cover for protection. After rain, remove the cover to allow the motorcycle to dry.



9.3 Transportation of Electric Motorcycle

If you need to transport your electric motorcycle, it is recommended to use an electric motorcycle trailer or a flatbed truck or trailer equipped with a loading platform, lifting platform, and electric motorcycle straps.

Before transporting the vehicle, try to align the front wheel of your electric motorcycle with the front of the trailer or truck. Additionally, use crossbars or sturdy, non-elastic straps to secure the vehicle at fixed points on the body, such as the frame, front fork, and rear flat fork.

Note

- Dragging an electric motorcycle can severely damage the transmission.
- If you need to manually carry the vehicle, please make sure to wear protective gloves. Avoid getting body parts pinched by the vehicle, especially the hubs, front and rear brakes, and other components during handling.

9.4 Your Impact on the Environment

Owning and riding an electric motorcycle can bring you unique enjoyment, but you must also fulfill your responsibility to protect the environment.

- **Selecting appropriate cleaners**
When cleaning your electric motorcycle, use biodegradable detergents. Avoid using sprays containing chlorofluorocarbons (CFCs), which can damage the ozone layer, the protective layer of the atmosphere.
- **Waste recycling**
Dispose of oil and other toxic waste in approved containers and take them to a recycling center. You can find recycling centers in your area and instructions for disposing of non-recyclable waste by calling your local or national public affairs or environmental protection service office.
Do not pour used gear oil into trash cans, sewers, or onto the ground.
Used oil, coolant, and cleaning solvents contain toxic substances that can harm cleaning workers and contaminate drinking water, lakes, rivers, and seas.
 - **Handling power battery**
If your motorcycle is beyond repair, consult your authorized dealer for instructions on disposing of the power battery.

10. Technical Specifications

10.1 Technical Specification Table

	Item		Parameters	
Basic parameters	Model		Hyperide-S (on-road model L1e)	Hyperide-R (off-road model)
	Length*width*height (mm)		1934*767*1070	1904*767*1092
	Wheelbase (mm)		1295	1291
	Ground clearance (mm)		242	254
	Saddle height (mm)		835	838
	Gross vehicle weight (kg)		≤87, 91	≤92
	Maximum load capacity (kg)		80	80
	Passenger capacity		One person	One person
Chassis system	Tire specifications	FR	90/90-17 TL	70/100-19 TT
		RR	120/70-17 TL	110/80-17 TT
	Shock absorbers	FR	Inverted hydraulic shock absorber S: 140mm	Inverted hydraulic shock absorber S: 140mm
		RR	Rear spoke with multi-connecting rods center-mounted single shock absorber 140mm	Rear spoke with multi-connecting rods center-mounted single shock absorber 140mm
	Brake system	FR	Floating dual-piston / disc brake φ220mm	Floating dual-piston / disc brake φ220mm
		RR	Floating single-piston / disc brake φ220mm	Floating single-piston / disc brake φ220mm
Transmission	Transmission type		Gear + chain	Gear + chain
	Reduction ratio		6.95	6.95
	Chain specification		428 UX	428 UX
Vehicle performance	Designed maximum speed		45km/h	75km/h
	Maximum climbing angle		≤20°	≤35°
	Driving range*		40 ~ 45km/70 ~ 75km	70 ~ 75km
Power battery	Battery type		Ternary polymer lithium battery	Ternary polymer lithium battery
	Nominal voltage (V)		72	72
	Nominal capacity (Ah)		20/35	35

Technical Specifications



	Item	Parameters	
Charger	Charger power	Slow charging: 6A (500W) / 10A (830W) Rapid charging: 10A (830W) / 20A (1660W) OP	Slow charging: 10A (830W) Rapid charging: 20A (1660W) OP
Motor	Type	Mid-mounted permanent magnet synchronous motor	Mid-mounted permanent magnet synchronous motor
	Rated voltage	72V	72V
	Rated power / peak power	2kw/4kw	3.5kw/7.5kw
	Peak torque	34N·m	45N·m
	Lubricating oil for reduction gear / capacity	GL-4 85W-90 (60mL)	GL-4 85W-90 (60mL)
Electrical equipment	Lights	LED	LED
	Instrument	3"VA color screen	3"VA color screen
	ECU	Bluetooth / GPS	Bluetooth / GPS
	Positioning module	4G	Without
	NFC	With	With
APP	With	With	

*The driving range is measured under normal temperature and humidity conditions, on a flat road surface, with standard tire pressure, a load of 80kg, and driving at a constant speed of 45km/h. Actual values may vary due to factors such as wind speed, road conditions, load, driving habits, and more. The values on this specification page are for reference only.

*The promotional images, features, and performance parameters in this user manual are for reference only. Please refer to the actual product for specific information.

*The right of final interpretation pertains solely to SHANGHAI EZICITI ENERGY TECH CO., LTD.

12. Index



A		
Accessories and modifications	9	
Anti-theft alarm system	22	
APP	26	
About the charger	39	
Adjustment of headlight beam	59	
B		
Braking	29	
Battery & charging	34	
C		
Charging port	18	
D		
Driving tips for maximizing range	3	
Disassembly of battery pack	36	
E		
Entire vehicle charging	37	
External charging	38	
Entire vehicle troubleshooting		60
F		
Fuse		58
Fault code table		62
H		
Handling unexpected incidents		8
Hill hold function		23
Hill descent control function		24
I		
Important information		4
Instrument		13
Indicators		14
Installation of battery pack		36
Importance of maintenance		42
Inspection of tire damage		49
Inspection of tire pressure		49
Inspection of tire tread depth		50
Inspection of brake fluid		52

Index

Inspection of brake pads and brake discs	53
Inspection and adjustment of chain slack	57
Inspection and replacement of fuse	58

K

Key points for safe riding	7
Kinetic energy recovery function	23

L

Loading guidelines	10
Left handlebar switches	15

M

Motor number	6
Main components	11
Maintenance	42
Maintenance schedule	43
Motor and controller	48
Maintenance of electric motorcycle	65

N

NFC wireless communication system	20
---	----

O

Overview	4
OTA upgrade function	23
Operating instructions for charger	40
Other information	65

P

Preface	1
Product label (Hyperide-S)	5
Preparation before riding	25
Parking	30
Power battery	34

R

Riding safety	7
Rider equipment	7
Right handlebar switches	16
Riding modes	19



Riding guidelines	25
Riding	28
Replacement of parts	44
Replacement of gear oil	56

S

Safety guidelines	7
Steering lock	31
Seat cushion	32
Spoke wheel (Hyperide-R)	51
Side stand	54
Storage of electric motorcycle	67
Schematic circuit diagram (Hyperide-S)	71

T

Torque management for key fasteners	45
Troubleshooting	48
Throttle grip	55
Transportation of electric motorcycle	68
Technical specifications	69
Technical specification table	69

U

Use of mechanical key	17
Use of NFC card	17

V

VIN	5
Vehicle information	5
Vehicle owner responsibilities	7
Vehicle introduction	11
Vehicle power on / off	26

Y

Your impact on the environment	68
--------------------------------------	----